

# CAST STEEL GATE VALVES



## Features:

- Flange Standard: ASME B16
- Face To Face: ASME B16.10
- Manufacturing as Per Standard API 600
- OS & Y Type Rising Spindle
- Testing as Per Standard API 598
- RF. ASTM A216 GR WCB

Sr. No.	Description	Material
1	Body	ASTM A216 GR WCB Cast Carbon Steel
2	Bonnet	ASTM A216 GR WCB Cast Carbon Steel
3	Wedge (Flexible)	ASTM A216 GR WCB+13% CR Steel
4	Seat Ring (Seal Weld)	ASTM A216 GR WCB+13% CR Steel
5	Spindle (Rising)	ASTM A276 GR 410 13% CR Steel
6	Bonnet Bush	ASTM A276 GR 410 13% CR Steel
7	Gland Bush	ASTM A276 GR 410 13% CR Steel
8	Gasket	Spiral Wound SS 316 With Graphite Filler
9	Gland Packing	Die Molded Grafoil Ring
10	Gland Flange	ASTM A105 Carbon Steel
11	Body Stud and Nut	A193 GR B7/A194 GR.2H Alloy Steel
12	Eye Bolt and Nut	A193 GR B7/A194 GR.2H Alloy Steel
13	Cross Bolt and Nut	A193 GR B7/A194 GR.2H Alloy Steel
14	Yoke Nut	ASTM A276 GR 410 13% CR Steel
15	Hand Wheel Nut	ASTM A36 Carbon Steel
16	Yoke Sleeve	ASTM A439 GR D2 NI-Resist
17	Hand Wheel Key	ASTM A36 Carbon Steel
18	Hand Wheel	Malleable Iron/SG Iron

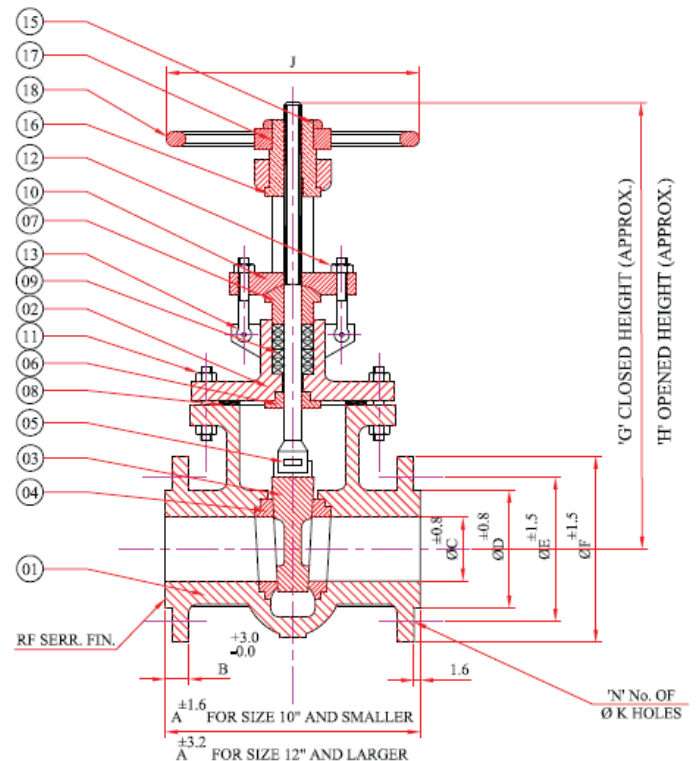

\* Due to the continuous development of our products, design or construction may change without prior notice.

# CAST STEEL GATE VALVES

## CLASS 150

### Torque

Size	Class	Lb.ft	N-m
2"	150	9.2	12.5
2 1/2"	150	10.4	14.1
4"	150	22	29.9
6"	150	38.9	52.7
8"	150	65.1	88.3
10"	150	102.7	139.2
12"	150	153.4	208



### Specification:

- Rated Pressure 300 PSI
- Shell (Body) Test Pressure 450 PSIG
- Seat/Back Seat Test Pressure 325 PSIG
- Pneumatic Test Pressure 100 PSI

### Dimensions and Sizes:

Sizes	A	B	C	D	E	F	G	H	J	K	N
2.0	7.008	0.630	2.008	3.622	4.764	5.984	10.315	16.575	7.874	0.748	0.157
2.5	7.480	0.630	2.559	4.134	5.512	7.008	13.858	18.425	7.874	0.748	0.157
3.0	7.992	0.748	2.992	5.000	5.984	7.480	18.228	21.496	9.843	0.748	0.157
4.0	9.016	0.945	4.016	6.181	7.480	9.016	23.071	23.701	9.843	0.748	0.315
6.0	10.512	0.984	5.984	8.504	9.488	10.984	28.504	35.039	13.780	0.866	0.315
8.0	11.496	1.142	7.992	10.630	11.732	13.504	35.354	44.094	13.780	0.866	0.315
10.0	12.992	1.181	10.000	12.756	14.252	15.984	40.827	51.654	15.748	0.984	0.472
12.0	14.016	1.260	12.008		17.008	19.016	45.079	57.874	19.685	0.984	0.472

# CAST STEEL GATE VALVES

## CLASS 300

### Torque

Size	Class	Lb.ft	N-m
2"	300	12.7	17.2
2 1/2"	300	15.9	21.6
4"	300	38	51.6
6"	300	88.2	119.6
8"	300	159.7	216.6
10"	300	262.1	355.4
12"	300	400.3	542.8



### Specification:

- Rated Pressure 750 PSI
- Shell (Body) Test Pressure 1125 PSI
- Seat /Back Seat Test Pressure 825 PSI
- Pneumatic Test Pressure 100 PSI

### Dimensions and Sizes:

Sizes	A	B	C	D	E	F	G	H	J	K	N
2.0	8.504	0.866	2.008	3.622	5.000	6.496	15.945	18.031	7.874	0.748	0.315
2.5	9.488	0.945	2.559	4.134	5.512	7.520	17.992	20.669	9.843	0.866	0.315
3.0	11.142	1.142	2.992	5.000	6.614	8.268	19.843	23.189	9.843	0.866	0.315
4.0	12.008	1.260	4.016	6.181	7.874	10.000	24.134	28.661	9.843	0.866	0.315
6.0	15.866	1.457	5.984	8.504	10.630	12.520	31.732	38.189	13.780	0.866	0.472
8.0	16.496	1.614	7.992	10.630	12.992	15.000	37.205	45.669	17.717	0.984	0.472
10.0	17.992	1.890	10.000	12.756	15.236	17.520	44.488	55.276	19.685	1.142	0.630
12.0	19.764	2.008	12.008	15.000	17.756	20.512	48.898	61.890	19.685	1.260	0.630

# CAST STEEL GATE VALVES

CLASS 600

## Torque

Size	Class	Lb.ft	N-m
2"	600	18.4	24.9
4"	600	72.1	97.7
6"	600	193.8	262.7
8"	600	358	485.4
10"	600	590.6	800.8



## Specification:

- Rated Pressure 1500 PSI
- Shell (Body) Test Pressure 2250 PSI
- Seat/Back Seat Test Pressure 1650 PSI
- Pneumatic Test Pressure 100 PSI

## Dimensions and Sizes:

Sizes	A	B	C	D	E	F	G	H	J	K	N
2.0	11.496	0.984	2.008	3.622	5.000	6.496	16.378	16.811	7.874	0.748	0.315
3.0	14.016	1.260	2.992	5.000	6.614	8.268	20.079	23.425	9.843	0.866	0.315
4.0	17.008	1.496	4.016	6.181	8.504	10.748	24.882	29.409	13.780	0.984	0.315
6.0	22.008	1.890	5.984	8.504	11.496	14.016	29.921	36.614	19.685	1.142	0.472
8.0	25.984	2.205	7.874	10.630	13.740	16.496	40.551	49.449	23.622	1.260	0.472
10.0	30.984	2.520	9.764	12.756	17.008	20.000	43.307	54.528	23.622	1.378	0.630